

PARTS LIST			
ITEM	QTY	PART NUMBER	DESCRIPTION
1	1	3029-5550-1	M/STEEL CRANKED STAY WELD ASSEMBLY - Z/C PASSIVATE
2	1	3029-5550-2	M/STEEL M16 WASHER 59.5 O/D - Z/C PASSIVATE
3	1	3029-5550-3	M/STEEL M16 NYLOC NUT - Z/C PASSIVATE
4	1	3029-5550-4	BLACK PLASTIC TUBE END PLUG

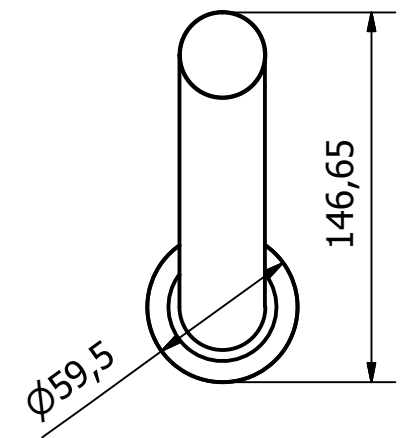
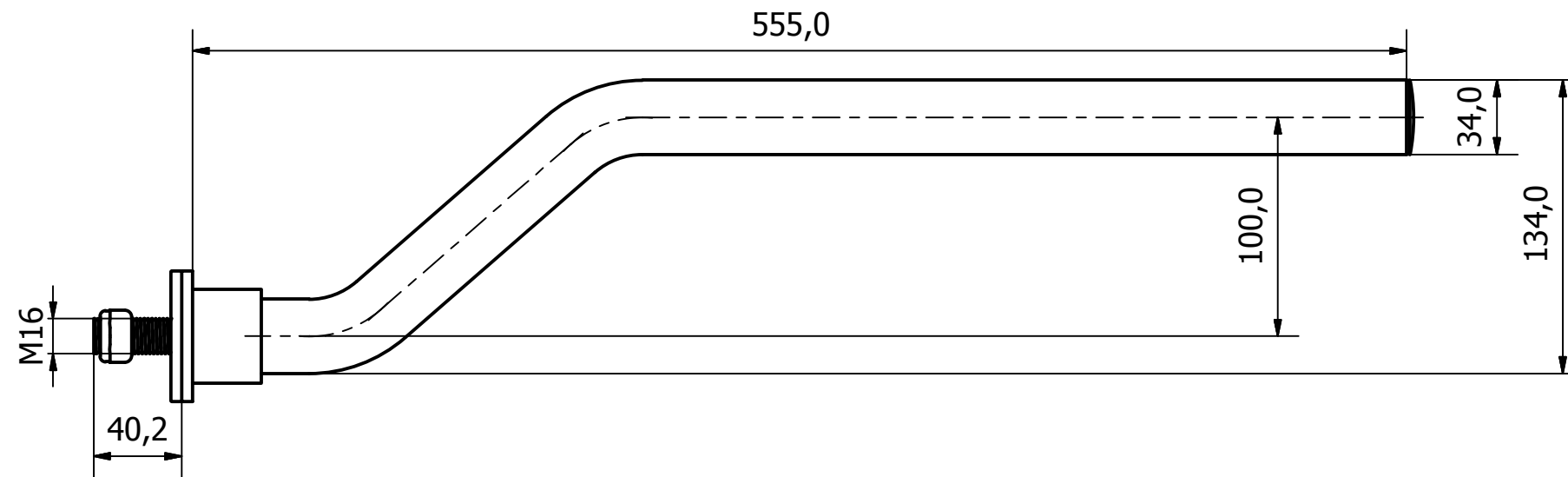
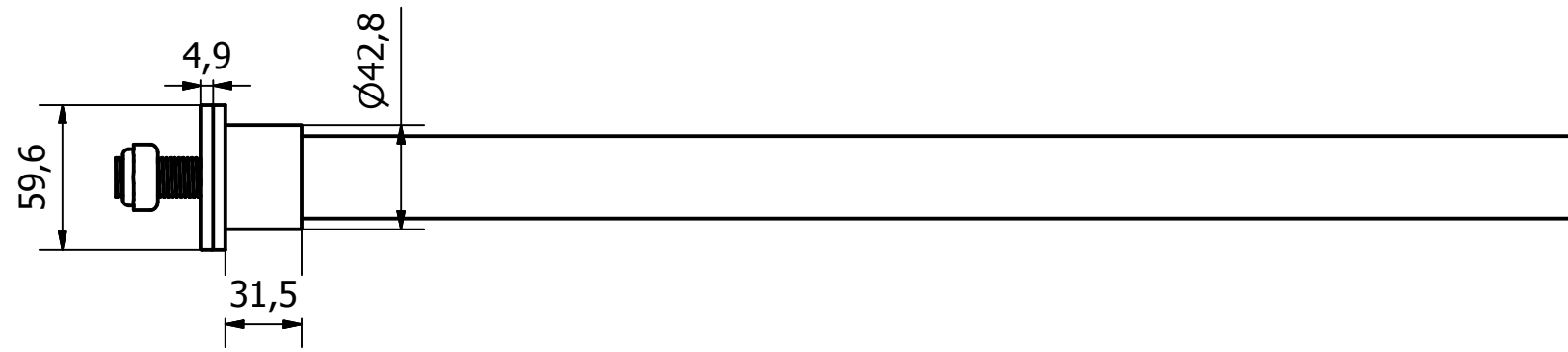
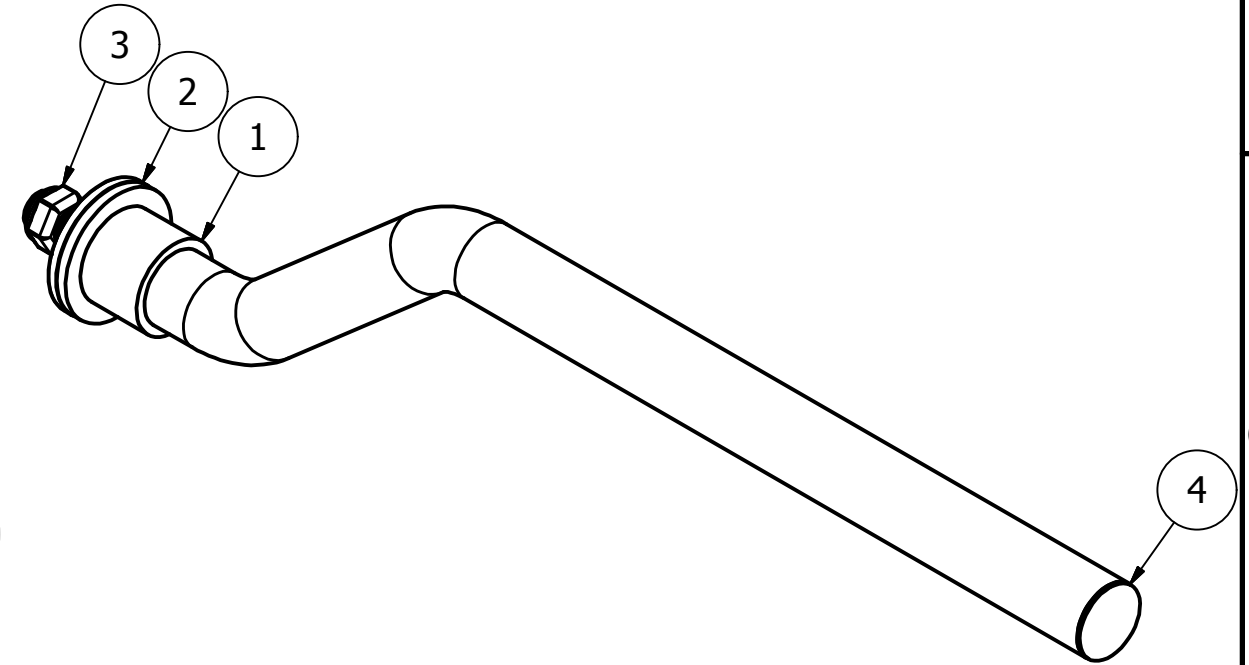

1	VALIDATION COMPLETE	31/08/17	A.P
REV	DESCRIPTION	DATE	APPROVED

GENERAL TOLERANCES ON LENGTHS
0.5 - 6 ± 0.1mm
6 - 30 ± 0.2mm
30 - 120 ± 0.3mm
120 - 400 ± 0.5mm
400 - 1000 ± 0.8mm
1000 - 2000 ± 1.2mm
2000 - 4000 ± 2.0mm

ALBERT JAGGER LTD
 GREEN LANE
 WALSALL PHONE: 01922 471000
 WEST MIDLANDS FAX: 01922 648021
 WS2 8HG

THIS DRAWING & THE DESIGN SHOWN ARE THE PROPERTY OF ALBERT JAGGER LTD AND MUST NOT BE USED OR COPIED BY A THIRD PARTY WITHOUT PERMISSION

DRAWN BY
U.F

CHECKED BY
A.P



SCALE
1 : 3

MATERIAL
SEE TABLE

MASS
2.931 kg

FINISH
SEE TABLE

Date
11/08/2017

ALL DIMS IN MM UNLESS STATED DO NOT SCALE

A3



M/STEEL CRANKED MUDGUARD STAY
 3029-5550

Edition	Sheet
1	1 / 1