

IF IN DOUBT ASK

ITEM NO.	PART NUMBER	DESCRIPTION	QTY.
1	2217-001-1	CARBON STEEL HINGE BASE	1
2	2217-001-2	BRASS BEARING WASHER	1
3	2217-001-3	CARBON STEEL MOUNTING BLOCK	1

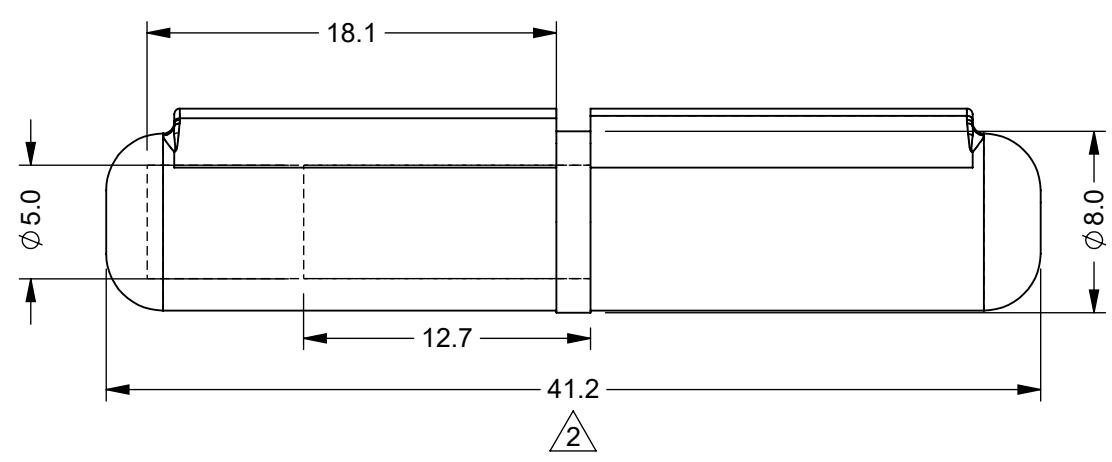
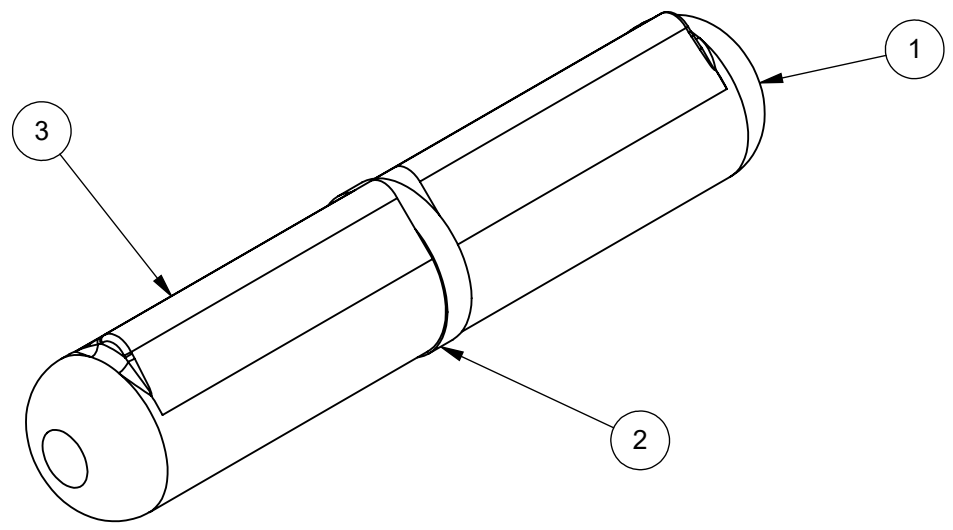
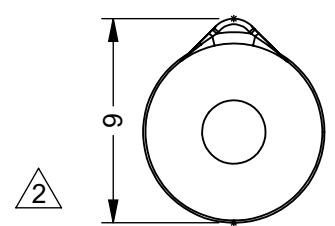
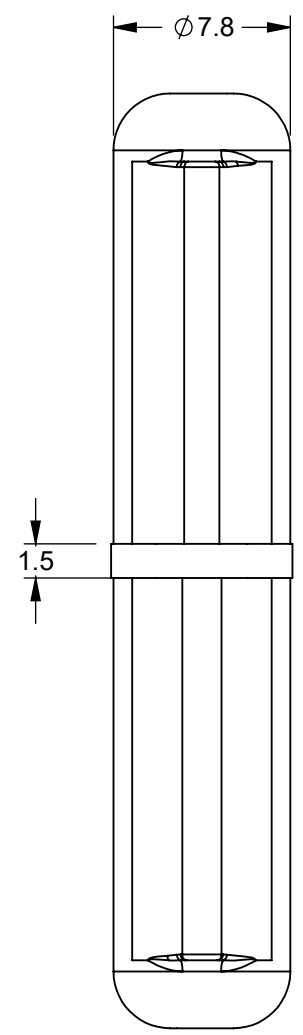

ZONE	REV.	DESCRIPTION	DATE	APPROVED
D7, E3	2	RE-DRAWN IN SOLIDWORKS, DIMENSIONS UPDATED	20/11/2023	L.B.H

REVISIONS

TOLERANCES			
0.5 - 6	= ±0.1mm	SURFACE FINISH	1.6µm Ra
6 - 30	= ±0.2 mm	FILLET RADII	0.5 TO 1.0
30 - 120	= ±0.3 mm	SQUARENESS	0.05 IN 25
120 - 400	= ±0.5 mm	PARALLELISM	0.05 IN 25
400 - 1000	= ±0.8 mm	RUNOUT	0.1
1000 - 2000	= ±1.2 mm	ANGLES	±0.5°
2000 - 4000	= ±2.0 mm		

MATERIAL: SEE TABLE	DRAWN BY: L.B.H	DESCRIPTION: WELD ON LIFT - OFF HINGE - 41.2 O/A			A3
MASS: 0.015	CHECKED BY: U.F	NUMBER: 2217-001	REVISION: 2	SHEET: 1 of 1	
FINISH: NATURAL	APPROVED BY: A.P	ORIGINATION DATE: 20/11/2023	SCALE : PROPORTIONAL - DO NOT SCALE REF SCALE 2:1 WHEN PRINTED ON A3		

PROPRIETARY RIGHTS ARE INCLUDED IN THE INFORMATION DISCLOSED HEREIN. NEITHER THIS DOCUMENT NOR ANY INFORMATION DISCLOSED SHALL BE REPRODUCED, USED, TRANSFERRED TO OTHER DOCUMENTS, OR DISCLOSED TO OTHERS FOR ANY PURPOSE INCLUDING MANUFACTURING UNLESS SPECIFICALLY AUTHORISED IN WRITING
REMOVE ALL SHARP EDGES AND BURRS
PART FINISHING AND MARKING TO CESF001

