

A IF IN DOUBT ASK

B

C

D

E

F

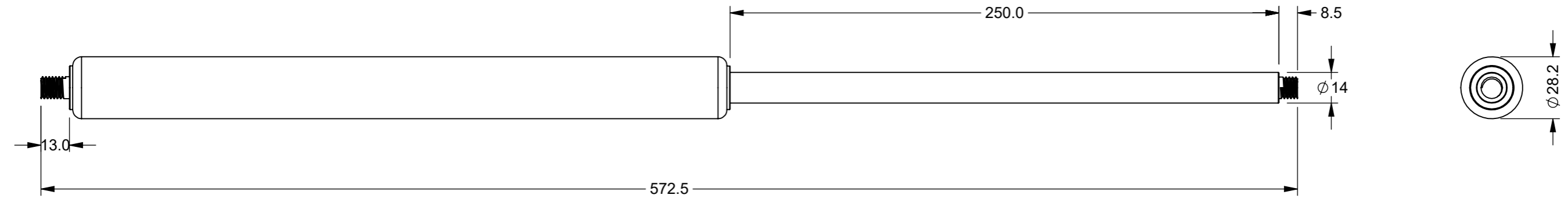
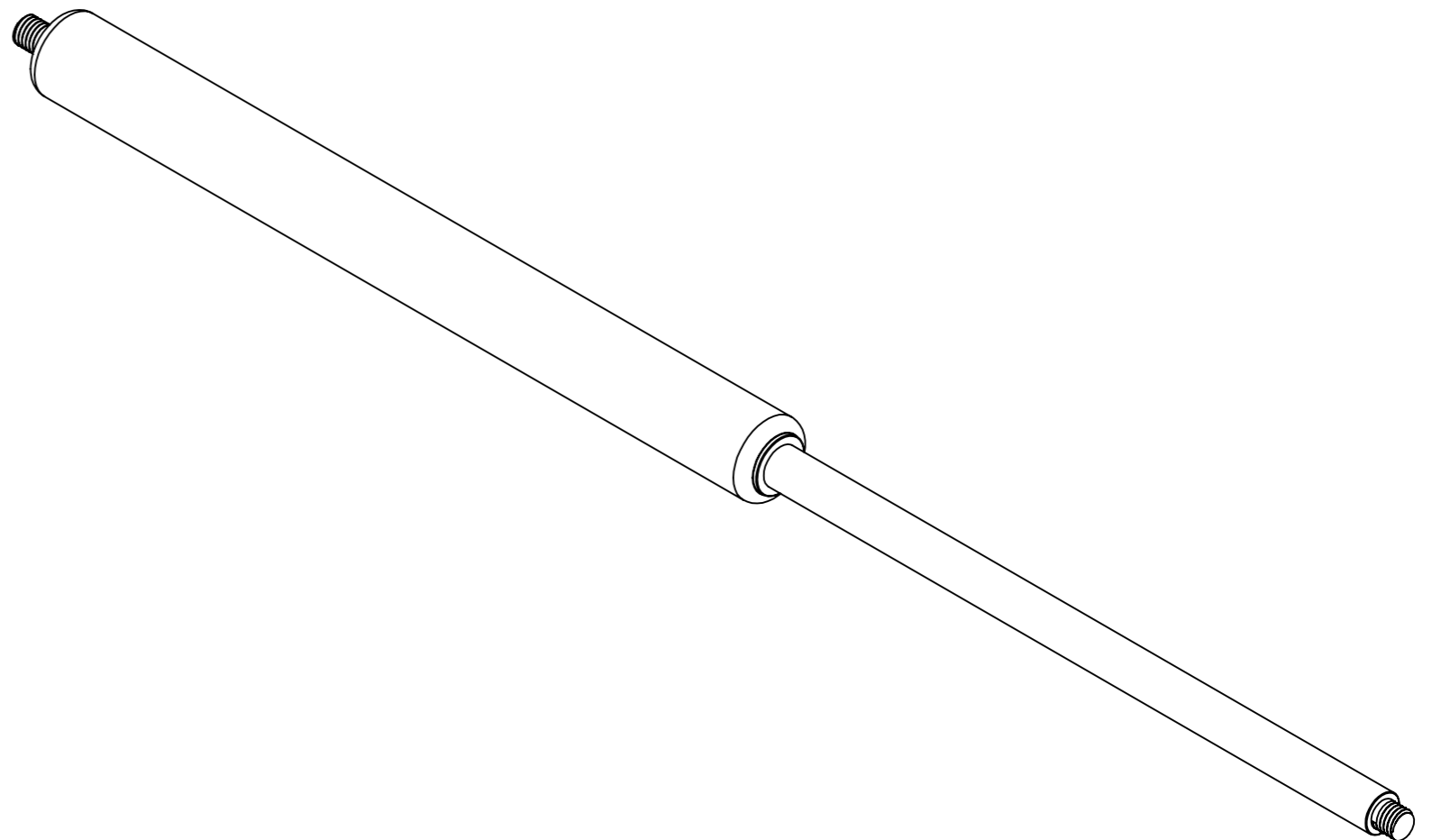

	1	VALIDATION COMPLETE	25/01/2024	AP
ZONE	REV.	DESCRIPTION	DATE	APPROVED

REVISIONS

NOTE:
EXTENSION FORCE / N : 1500

UNLESS OTHERWISE STATED, ALL DIMENSIONS IN mm

TOLERANCES		SURFACE FINISH 1.6µm Ra	
0.5 - 6	= ±0.1mm	FILLET RADII	0.5 TO 1.0
6 - 30	= ±0.2 mm	SQUARENESS	0.05 IN 25
30 - 120	= ±0.3 mm	PARALLELISM	0.05 IN 25
120 - 400	= ±0.5 mm	RUNOUT	0.1
400 - 1000	= ±0.8 mm	ANGLES	±0.5°
1000 - 2000	= ±1.2 mm		
2000 - 4000	= ±2.0 mm		

MATERIAL: M/STEEL	DRAWN BY: SR	DESCRIPTION: GAS SPRING ; DOM0-45-250-(7282)-1500N			A3
MASS: 1.78KG	CHECKED BY: AP	NUMBER: 1260-7282	REVISION: 1	SHEET: 1 of 1	
FINISH: BLACK	APPROVED BY: AP	ORIGINATION DATE: 25/01/2024	SCALE : PROPORTIONAL - DO NOT SCALE REF SCALE 1:5 WHEN PRINTED ON A3		



PROPRIETARY RIGHTS ARE INCLUDED IN THE INFORMATION DISCLOSED HEREIN. NEITHER THIS DOCUMENT NOR ANY INFORMATION DISCLOSED SHALL BE REPRODUCED, USED, TRANSFERRED TO OTHER DOCUMENTS, OR DISCLOSED TO OTHERS FOR ANY PURPOSE INCLUDING MANUFACTURING UNLESS SPECIFICALLY AUTHORISED IN WRITING
REMOVE ALL SHARP EDGES AND BURRS
PART FINISHING AND MARKING TO CESF001