

IF IN DOUBT ASK

A

B

C

D

E

F

A

B

C

D

E

F

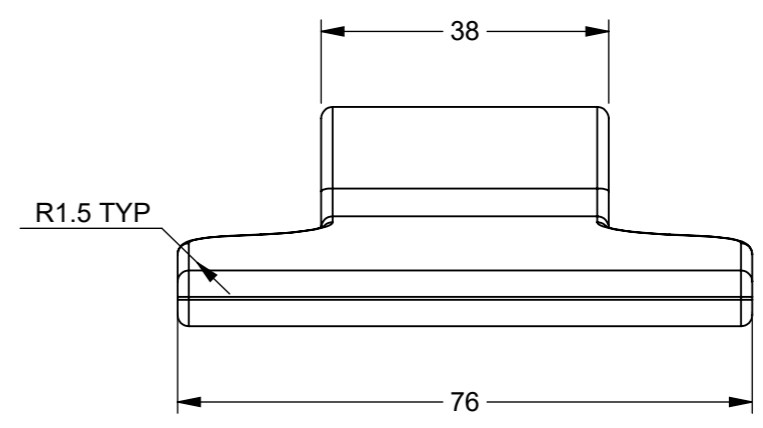
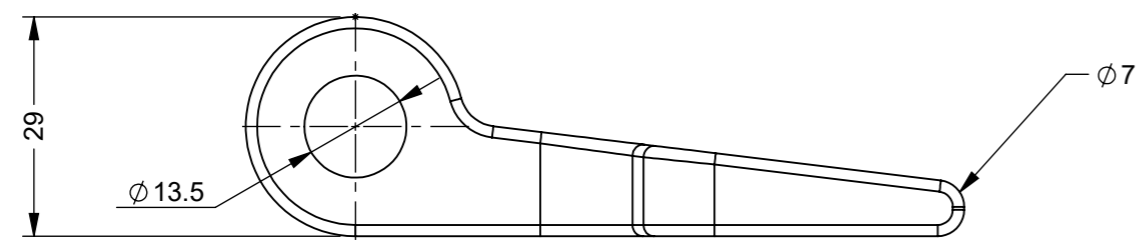
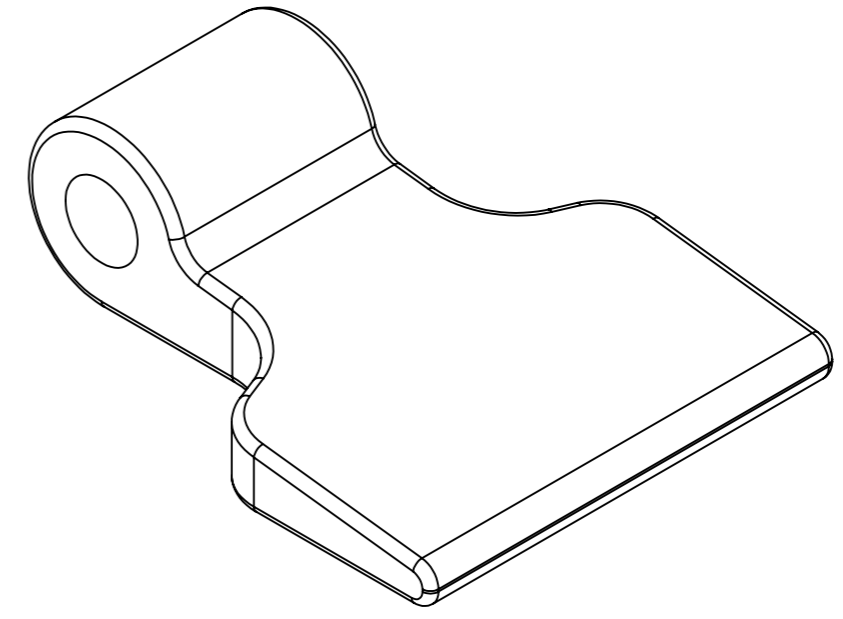
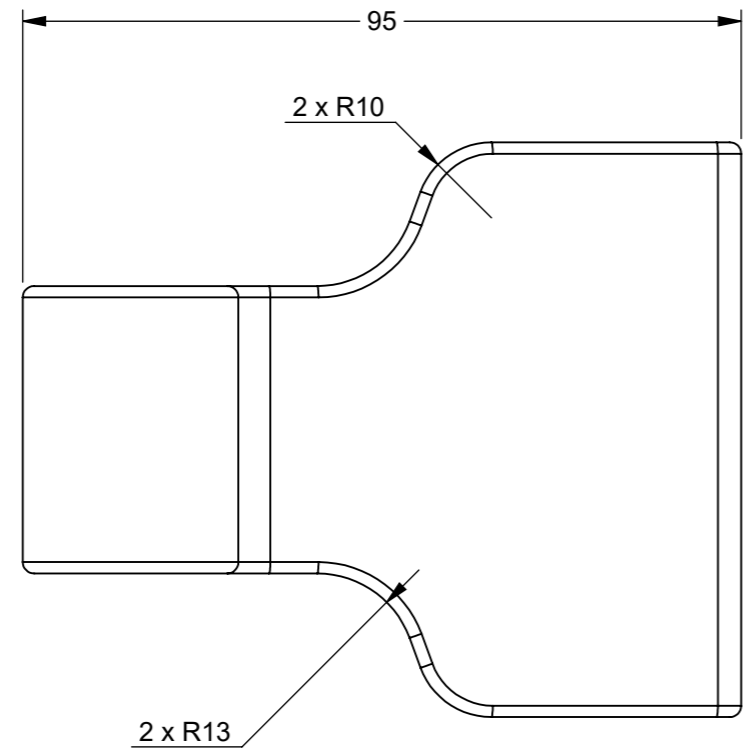

ZONE	REV.	DESCRIPTION	DATE	APPROVED
	3	RE-DRAWN TO NEW SAMPLE	09/06/2023	U.F

REVISIONS

UNLESS OTHERWISE STATED, ALL DIMENSIONS IN mm

TOLERANCES	SURFACE FINISH	FILLET RADII
0.5 - 6 = ±0.1mm	1.6µm Ra	0.5 TO 1.0
6 - 30 = ±0.2 mm		
30 - 120 = ±0.3 mm	SQUARENESS 0.05 IN 25	
120 - 400 = ±0.5 mm	PARALLELISM 0.05 IN 25	
400 - 1000 = ±0.8 mm	RUNOUT 0.1	
1000 - 2000 = ±1.2 mm	ANGLES ±0.5°	
2000 - 4000 = ±2.0 mm		

MATERIAL: FORGED STEEL	DRAWN BY: UF	DESCRIPTION: FORGED TAILBOARD HINGE - WELD ON			A3
MASS: 0.47	CHECKED BY: A.P	NUMBER: 1032-001	REVISION: 3	SHEET: 1 of 1	
FINISH: NATURAL	APPROVED BY: A.P	ORIGINATION DATE: 08/06/2023	SCALE : PROPORTIONAL - DO NOT SCALE REF SCALE 1:1 WHEN PRINTED ON A3		

PROPRIETARY RIGHTS ARE INCLUDED IN THE INFORMATION DISCLOSED HEREIN. NEITHER THIS DOCUMENT NOR ANY INFORMATION DISCLOSED SHALL BE REPRODUCED, USED, TRANSFERRED TO OTHER DOCUMENTS, OR DISCLOSED TO OTHERS FOR ANY PURPOSE INCLUDING MANUFACTURING UNLESS SPECIFICALLY AUTHORISED IN WRITING
REMOVE ALL SHARP EDGES AND BURRS
PART FINISHING AND MARKING TO CESF001

