

6 1 5 1 4 3 1 2 1 1

D D

C C

B B

A A

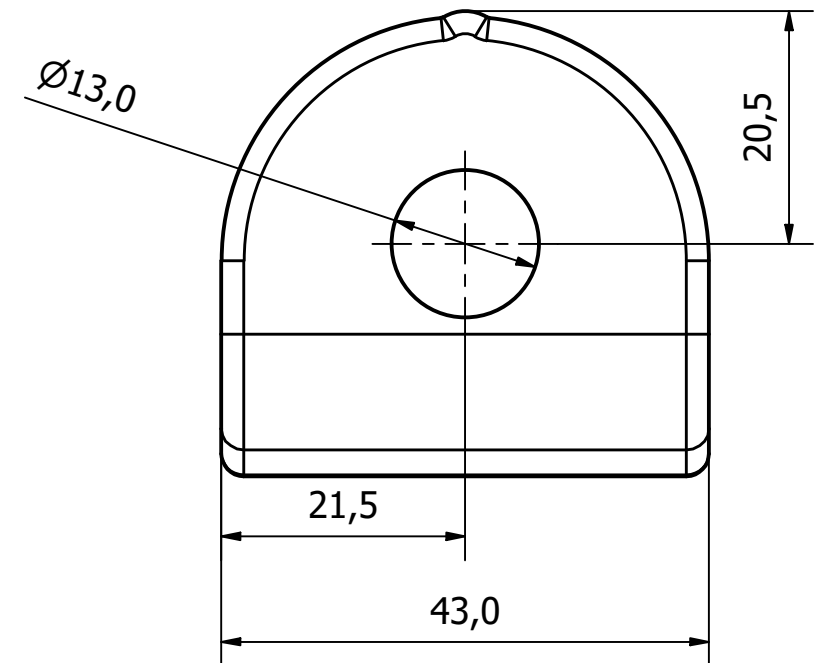
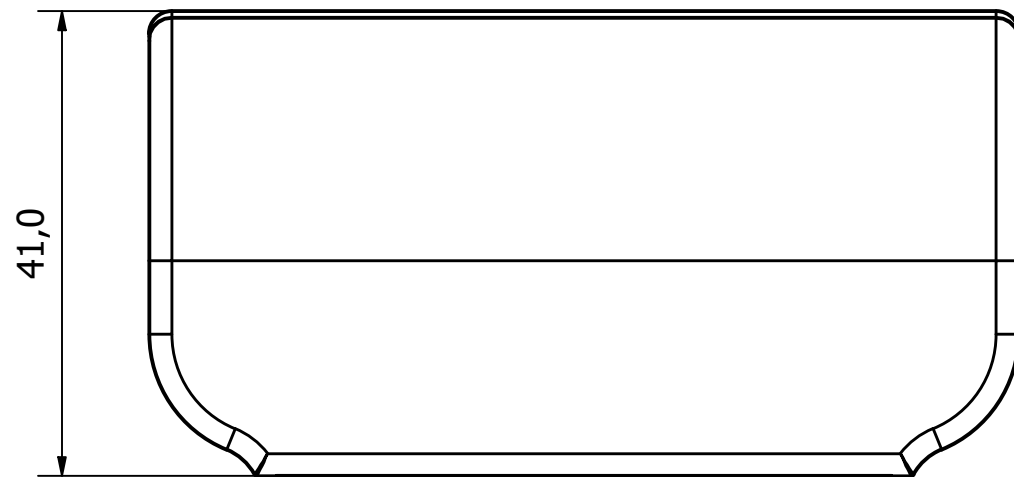
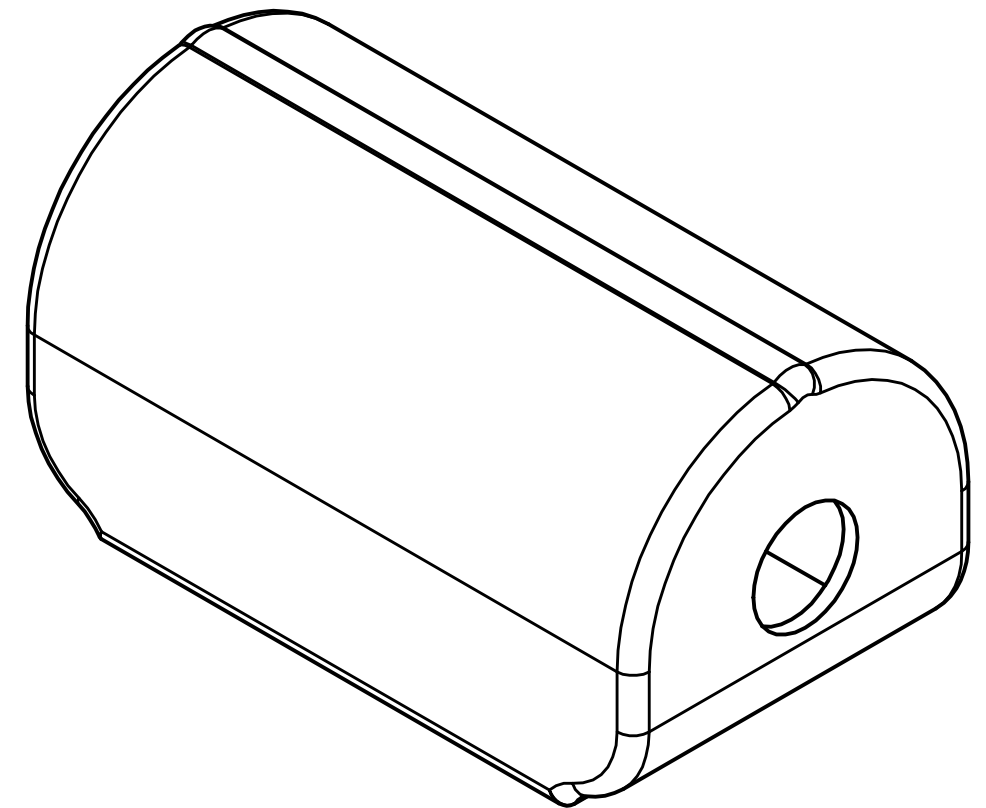
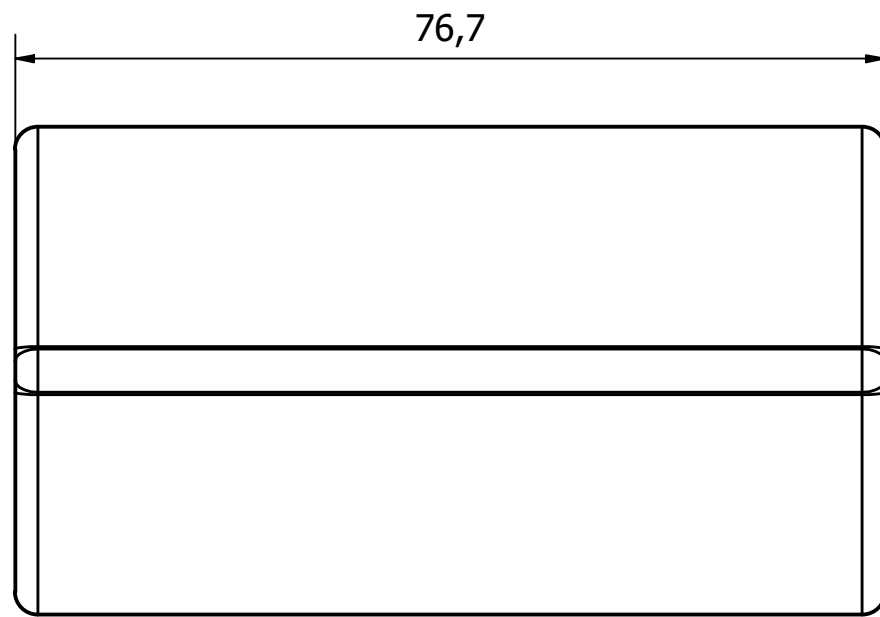

PLASTICISED PVC IS UV STABLE, HAS 75° SHORE HARDNESS AND IS COMPATIBLE WITH THE FOLLOWING SPRING BOLTS:

0837/001 (ZINC PLATED M/STEEL)
0837/020 (STAINLESS STEEL)

PART No.	FINISH
0837/010	BLACK
0837/011	RED

GENERAL TOLERANCES ON LENGTHS
0.5 - 6 ± 0.1mm
6 - 30 ± 0.2mm
30 - 120 ± 0.3mm
120 - 400 ± 0.5mm
400 - 1000 ± 0.8mm
1000 - 1200 ± 1.2mm
2000 - 4000 ± 2.0mm

ALBERT JAGGER LTD
GREEN LANE
WALSALL PHONE: 01922 471000
WEST MIDLANDS FAX: 01922 648021
WS2 8HG

THIS DRAWING & THE DESIGN SHOWN ARE THE PROPERTY OF ALBERT JAGGER LTD AND MUST NOT BE USED OR COPIED BY A THIRD PARTY WITHOUT PERMISSION

DRAWN BY
U.F

CHECKED BY
A.P

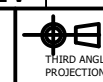

SCALE
1.5:1

MATERIAL
PLASTICISED PVC

MASS
0.024 kg

FINISH
SEE TABLE

Date
19/12/2016

ALL DIMS IN MM UNLESS STATED DO NOT SCALE

A3

1	VALIDATION COMPLETE	15/02/17	A.P
REV	DESCRIPTION	DATE	APPROVED



SPRING BOLT COVER	
0837-011	
Edition 1	Sheet 1 / 1

6 1 5 1 4 3 1 2 1 1